

# **Laboratory Animal Production & Management**

**LPM-604**

An animal which has more or less similar physiological and body composition with various biological systems as human beings, which are tiny, easy to handle, less expensive and co-operative are called as laboratory animals.

### Types of Laboratory animals:

Mice, Rats, Hamster, Guinea Pigs, Rabbits, Monkeys and Transgenic Fly are popular Laboratory animals.

## Classification of Laboratory animals:

### ❖ Conventional animals: -

Animals derived and grown in general environment but free from diseases communicable to human like mycobacteria, Dermatophytic fungi, Pasteurella and Sarcoptes Scabiei.

### ❖ Gnotobiotic animals: -

Animals with known microbes such as virus, bacteria, fungi and protozoa is said to be gnotobiotic animals. This animal has to be bred in controlled environment in the equipment called isolator. They are foundation stocks for producing specific pathogen free animals. Gnotobiotic rats & mice are used to study carcinogenesis, immunology, toxicology, nutrition etc.

## ❖ **Specific Pathogen Free Animals: -**

An animal which is made free from specific or particular microbe is known as SPF animals.

## ❖ **Germ free animals: -**

An animal which don't have any demonstrable microbe is known as germ free animal. This can be achieved by killing the mother with cervical dislocation and removing the foetus by hysterectomy without any anaesthetic in an isolator.

Young ones must be reared in a isolator in germ free environment. The feed and water also must be provided after sterilisation.

These animals are useful:

- To study role of microbes in nutrition.
- To study physiology without infection.
- To conduct biological, toxicological & microbiological assays.

## **Mice: -**

They are smaller in size, early puberty, high fecundity, short gestation, high position in evolutionary scale. Due to these specialties about 60-70% laboratory animals are used as mice.



## **Rat: -**

Nearly 2-3 times bigger in size than mice, short gestation, prolific breeder, early puberty and high fecundity.



## Guinea Pig: -

- It is prolific breeder, easy to rear and breed in captivity.
- Gestation period is comparatively little bit longer than Rat & Mice.
- It needs supplementation of Vit. C in the diet and
- More susceptible to T.B. & Anaphylactic shock.



## Hamster: -

- Syrian and Chinese are two popular varieties of hamster used in various research specifically Riboflavin and Vit. E deficiencies.
- Chinese hamster are commonly used in research on diabetes due to high incidence of diabetes mellitus in them.
- It has low (22) chromosomal No. Due to which they are useful in cytological study, tissue culture, genetics & radiation research.





## Transgenic Fly: -

These flies bred quickly and have short life time of about 15 days. To carry out biological assay in fly is much cheaper as compared to other laboratory animals.



## Rat

## Mice

Fur of rat is coarse.

Fur is Smooth

Tail of rat is thicker and well serrated  
(notches on edge)

Thinner and non-serrated

Skin of rat is thick

Thin

Rat is bigger in size and heavy in  
weight

Mice is smaller and light in weight

## Biological & Physiological data of laboratory animals:

Parameters	Mice	Rat	Guinea Pig	Hamster Syrian/Chines e	Rabbit
Birth Weight (gm)	1-1.5	6-7	70-100	20	50-70
Body weight (adult gm)	30-40	250	800	80-90/35-40	1500-5500
Daily feed consumpt.(gm)	5-6	15-20	45-50	10-15/10	200-250
Age of first mating (M)	1.5-2	2.5-3	3	2-3/2-3	6-7
Age for experiment(M)	45(days)	1.5	3	1/1	6
Heart rate (beat/min.)	330-750	310-500	250-400	315-410/310- 400	150-300
Respiration rate /min.	85-230	70-180	70-110	35-130/30-125	40-60
Sex ratio (Male : Female)	1:3	1:5	1:6	1:1/1:1	1:1

Parameters	Mice	Rat	Guinea Pig	Hamster Syrian/Chines e	Rabbit
Blood Volume (% of Body Wt.)	7-10	5-7	6-12	6-9/6-10	5-8
Life span (Years)	1.5-2.5	2-3	3-5	2-3/2-3	5-6
Gestation period (Days)	20-21	21-22	65-67	16/21	31-32
Litter size	7-12	8-10	3-4	5-7/4-5	6-8
Age at Weaning (Weeks)	3	3	2-3	3½/3	7
Litter/year	8-10	7	4-5	10/7	4-5
Rest period for females in between 2 mating(days)	15	15	15	18/15	20
No. Of pairs of mammary gland	5	5	1	6-7/4	3-4

- Laboratory animals require elaborated housing with adequate ventilation and space to move.
- The house should provide protection from weather, predators, mosquitoes and insects.
- Laboratory animals can be housed on floor or in cages in groups in the house.
- The space requirement mostly depends on body weight and size. Formula to calculate floor space for laboratory animals is:

$$A = n (3W + 5\sqrt{W}) \text{ in square inches.}$$

$$A' = n (0.7W' + 6\sqrt{W'}) \text{ in square cm.}$$

Where A or A' = Floor space

W or W' = Wt. Of animals (W = Wt. In ounce and W' = Wt. In grams) and n = no. Of animals.





## Floor space requirement:

Animal	Area (cm <sup>2</sup> )	Height of cage (cm)
Mice	38-99	17.5
Rat	110-260	22.5
Hamster	64-125	22.5
Guinea Pig	270-650	35



## Site of housing: -

- ❖ Higher elevation
- ❖ Minimum access to visitors
- ❖ Minimum noise disturbance
- ❖ Separate from main biological/Immunological production unit
- ❖ Away from polluted area.

## Types of housing: -

1. Non-air conditioned
2. Air conditioned

**Non-air conditioned:** - The direction of air flow should be taken into consideration while constructing those houses. The air flow should not directly enter the entrance of house. The house should have 2 corridors.

- a. **Clean corridor:** - This is place in front of animal room and used-
- To bring in sterile food/feed.
  - To take in autoclaved cages.
  - To take bedding materials in the house.
  - A foot dip with antiseptic/disinfectant solution be provided at the entry of the clean corridor which facilitates reduction of microbes infiltration in house.
  - The door of entry should open outside so that hot and light air will rush outside after opening the door, which help in checking the infiltration of outside infection in the house.
  - The house must be free from rodents as well as insects like mosquitoes, cockroaches, bugs, flies etc.

- b. Dirty corridor:** - This is placed at backside of animal house and used
- To remove the garbage by having a washing room.
  - To check contamination of incoming food/feed by removing garbage by separate outlet.
  - To prevent direct cold draft or entry of sunlight in animal rooms.

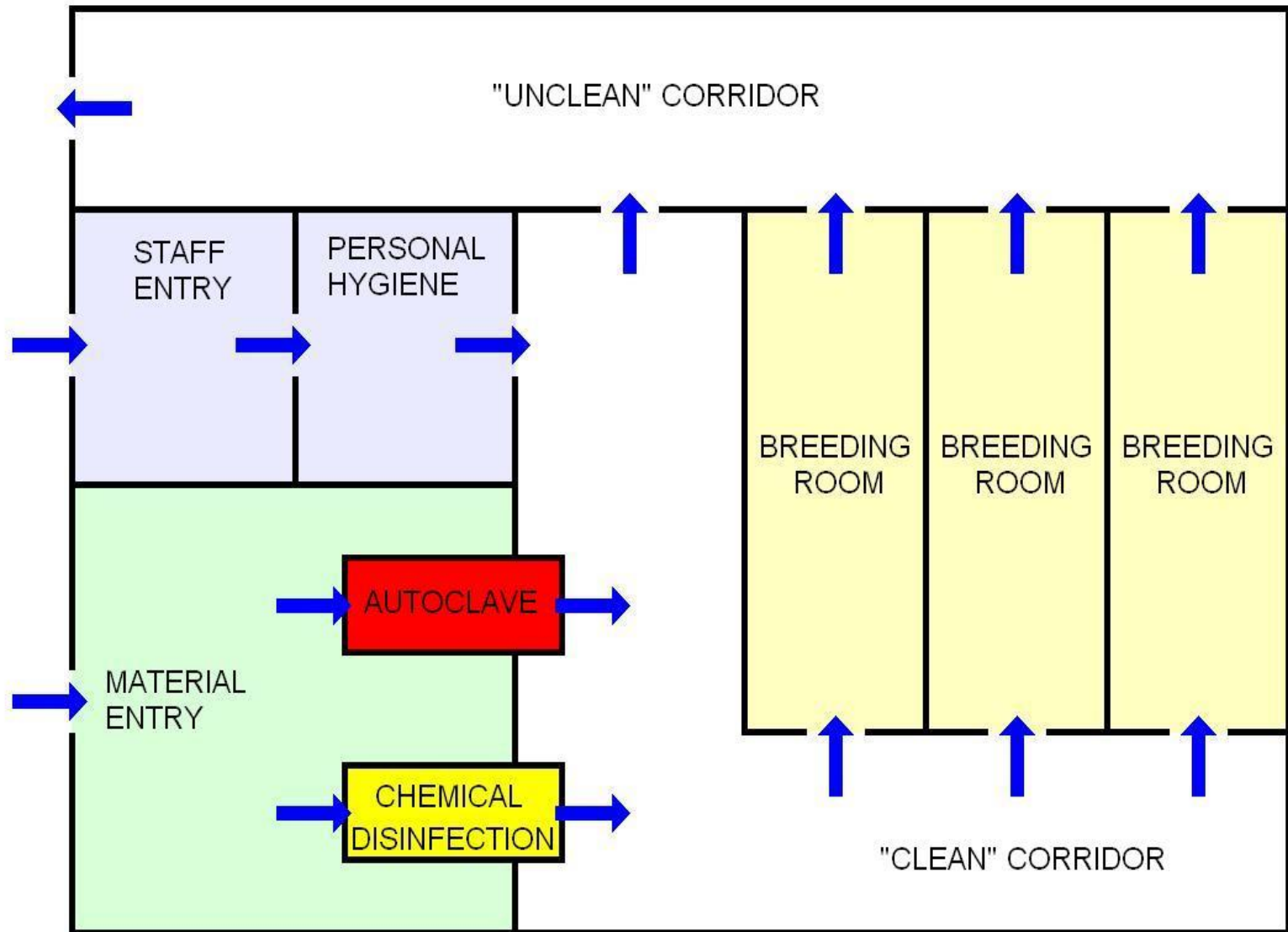

## **Housing Standards:**

**Mice:** 3.5x 4.5 m i.e. 15.75m<sup>2</sup> room for 200-300 mice in cages on racks.

25cm Length x 15cm width x 22.5cm height  
4 adults mice or 10-12 weaners.

### **Rat:**

40-45cm length x 25-30cm width x 37.5cm height.  
2 females + 1 male.

### **Hamster:**

40-45cm length x 25-30cm width x 37.5cm height.  
2 females + 1 male.

### **Guinea Pig:**

0.91m length x 0.45m width x 0.45m height.  
2 females + 1 male.

# Strains and Breeding of Laboratory animals

**Mice:** The common strains are **Swiss Albino, Kausali, NIN, CBA, C-57, Bulb-S, CH-3** etc. **Swiss Albino** is most popular.

## **Rat:**

- ❖ The rat has blocky body with comparatively rough hair, long pointed snout, prominent long ears and sharp teeth.
- ❖ The body length is around 14-16cm, tail is 16-20cm.
- ❖ Adult weight 100-250gm.
- ❖ The common strains are- **Wister, Sprague, Dawley, Charles Foster and Long Evans.**

## **Hamster:**

- ❖ **Syrian and Chinese** are two popular strains.
- ❖ They have chunky body with short legs, a fluffy tail, loose skin with dense, short and soft fur.
- ❖ The front legs have four toes whereas hind legs possess five toes.

- ❖ Adult hamster is 16cm in length and weigh 90-125gm.
- ❖ The Chinese hamster are only 9cm in length weighing 55gm. Hence also known as Dwarf hamster.
- ❖ Chinese hamster have dorsally grey colour with black strip in the centre.
- ❖ Syrian hamster are golden brown dorsally with little black ventrally.

### Guinea Pig:

- ❖ **Peruvian, English and Abyssinian** are popular strains.
- ❖ They are short rodents without tail. Head is blunt and rectangular. The neck is thick and so short merged with body.
- ❖ The hind legs are longer than forelegs.
- ❖ The weight of male is 800-1600gm and in females 700-1300gm.

## Transgenic Fly: -

This is a new fruit fly developed by L. S. Shashidhara and Poonam Bhandari at Centre for Cellular and Molecular Biology (CCMB) at Hyderabad through genetic engineering in 2000.



## Mice and Rat:

Nature: - Prolific breeder

Puberty: - 4 to 6 weeks

Mating: - 8 to 9 weeks, early mating reduces fertility.

Estrous duration: - 4 to 5 days.

Gestation period: - 20 to 22 days.

Birth weight of young ones: - 1 to 1.5gm

Litter size: - 10 to 12

Weaning weight: - 10 to 12gm and age 21 days.

## Detection of successful mating:

Presence of sperm in vagina smear or copulatory plug (solidified semen) in vagina.

Lee boot effect: -

When large group of females are housed together they go into anestrus by due pseudopregnancy which is known as lee boot effect.

Whitten effect: -

When such females are housed again with male, within 72 hours they will exhibit regular estrus, which is called as Whitten effect.

## Hamster:

Puberty: - 4 to 6 weeks.

Mating age: - 8 to 12 weeks.

Weight at mating: - Syrian- 80 to 90gm

Chinese- 35 to 40gm

Estrus duration: - 4 to 5 days.

Mating: - Hand mating is followed.

Gestation period: - 16 to 18 days.

Litter size: - 5 to 7

Weaning age: - 20 to 25 days and weight 15gm.

Male and female housed in separate quarters, brought together only at the time of mating and separated again immediately after mating, otherwise female may cause serious injuries to tail and testes of male.

Estrus sign: - Stringy, translucent mucus is extruded initially turning into creamy white discharge in later period with odour. Well receptive female exhibits typical lordosis posture (Crouching with hind quarters raised). Mating takes usually on 4<sup>th</sup> day.

### Guinea Pig:

Puberty: - 4 to 5 weeks.

Mating age: - 9 to 11 weeks.

Weight at mating: - Male- 900 to 1500 gm

Female- 700 to 1300gm.

Estrous sign: - Hip swaying, mounting activity, unsteady movements.

Mating: - Polygamous

Farrowing: - Communal i.e., group of females farrows in common pen.

Gestation: - 60 to 75 days.

Birth weight: - 45 to 50gm.

Litter size: - 5 to 6.

Weaning weight: - 160 to 230gm.

As per utility of animals and facilities available breeding methods is recommended.

1. **Monogamy:** - Involves pairing of single male and female. Method is useful for inbreeding of stocks and usually pair is kept for life long.
2. **Polygamy or Harem method:** - This consists of keeping together one male and more than one females in one cage. Normal male to female ratio recommended is 1:2-6 (Mice & Rat), 1:10 (Guinea Pig), 1:7 (Hamster).
3. **Continuous mating:** - Mating occurs immediately or within few hours after parturition. In inbred mice in monogamous mating males are not separated and mating is continuous.

4. **Discontinuous mating:** - Female is separated from male sometime before parturition, to avoid post-partum mating. Mating is advocated after lactation i.e. During post lactation oestrous.

### Breeding systems: -

- 1) Inbreeding
- 2) Out breeding
- 3) **F1 generation breeding:** - To reduce the biological diversity in out bred animals and check the inbred drawbacks, it is better to select F1 (first filial) generation of progeny have more homozygosity for breeding than two heterogenous parents. F1 generation also has hybrid vigour due to optimum heterozygotes state and have equal homozygosity. Hence can be very well used to conduct biological & immunological research.

## Selection of laboratory animals for breeding:

- Animals selected for breeding should have good parental record like production, progeny, litter size and mothering ability.
- Animals must be physically fit and healthy.
- Animals which is bigger in litter be preferred.
- If litter consists more males and less female, the whole litter should be rejected.
- Animals exhibiting vices must be rejected.
- There should not be any discharge form ear, nose and eyes.
- The animal to be selected should be alert, vigorous, clean and off standard size.



Laboratory animals are mostly smaller in size and more delicate, so handling is very important. Gentle handling is the best way to obtain real and correct experimental results.

### Purpose of handling:

1. Housing
2. Weighing
3. Inoculation & sample collection
4. Inspection to note body changes
5. Marketing and transport.

## Methods of handling:

**Mouse:** - Mouse should be quickly and firmly picked by grasping base of tail to lift slightly upward. For examination, grasp the scruff at the base of neck with thumb and index finger by one hand (mostly left hand). Support tail of animal with 4<sup>th</sup> or 5<sup>th</sup> finger.

**Rat:** - Rats should not be hold for longer time with tail grip because they get irritated and try to bite. After grasping by one hand, immediately grip rat with other hand by placing 2<sup>nd</sup> and 3<sup>rd</sup> finger on either side of mandible through the neck, whereas 4<sup>th</sup> & 5<sup>th</sup> finger should be placed on chest.

**Hamster:** - The hamster must be picked up confidently and gently because improper handling tends to bite. It should be grasped with large pinch on the scruff with palm and other fingers to hold.

**Guinea Pig:** - Guinea pigs can be lifted by placing thumb and other fingers over either sides of neck by one hand and then support body with other hand under the caudal end of animal.

## Identification of laboratory animals:

1. **Staining:** - Painting the animal with dyes like crystal violet, carbol fuschin etc. can be conveniently used for marking. Staining on skin coat on small area will easily visual.
2. **Tagging/Branding:** - Rabbits and Guinea pigs can be ear tagged. Aluminium tags with embeded numbers are normally used.
3. **Tattooing:** - usually carried on ears, foot, shoulders or hip for identification.
4. **Notching:** - Cutting ears in specific shape at particular place in the form of notch is also used as identification marks in rats and mice.

## Feeding of laboratory animals:

Feed/food for lab. Animals should not be stored for longer duration because it loses its nutritive value and leads to reduce acceptability.

## Feeding raw materials:

- Rodents are naturally grain eaters, hence their feed formulation should consist of large quantity of grains, seeds and nuts.
- Usually more than one grain is mixed together to compensate deficiency in one grain by another.
- Common raw materials used for preparing feed are crushed maize, whole wheat, barley, oat, sunflower seed, powdered millets, gram flour, salt, vitamin and mineral mixture etc. can be used.

- Greens like succulent grasses, Lucerne or berseem along with vegetables are fed in Guinea pig and rabbits.

### Feed form:

- Pellets are preferred instead of mash because mash get soared faster with difficulty of storing as well as it is messy, unhygienic and laborious to prepare.
- Pellets are commercially available for feeding lab. Animals.

## Feeding of mice and rat:

- These animals take small bites of food or pellets.
- They pull the pellets through wire mesh, hold in front leg and then eat.
- Their food should contain 16 to 20 % protein, 4 to 5% fat and 45 to 50% carbohydrate.
- Daily requirement: Rat 15gm and Mice 6gm.

Raw materials	Proportion of mixing (%)
Wheat flour	75.0
Gram flour	10.0
Skimmed milk powder	10.0
Refined oil	10.0
Salt	1.0
Vitamins and Minerals	3.5
Total	100.0

## Feeding of Hamster:

- Hamster have cheek pouch. They eat faster and store in the pouch.
- Then they go to corner and chew the stored food slowly.
- Their feed consists of 16 to 20% protein, 4 to 5% fat and 45 to 50% carbohydrate.
- Daily feed requirement- 15gm.

## Feeding of Guinea Pig:

- Green grasses, leaves and vegetables chewing is main features of guinea pig feeding.



Raw materials	Proportion of mixing (%)
Wheat bran	20.0
Whole grams	10.0
Carrots or Cabbage	10.0
Lucerne	60.0
Total	100.0

### Nutrient composition:

- 16 to 25% protein, 4 to 5% fat, 45 to 50% carbohydrate and 10% fibre.
- Specially required nutrient is Vitamin C. Hence it should be supplement either through feed or water @ 250mg/Liter.
- Daily feed requirement- 60 to 70gm.

# Disease and health care

Like other animals Laboratory animals are susceptible to many viral, bacterial, mycotic, parasitic and external pest infection. The disease may emerge and appear in the form of morbidity, mortality or outbreaks.

## Diseases of Mice:

### Bacterial: -

- **Salmonellosis:** causative agent are *S. Typhimurium* and *S. Enteritidis*.
- **Pasteurellosis:** Causative agent are *P. Pneumotropica*, *P. Muricida* and *P. Pestis*.
- **Mouse Septicaemia:** Causative agent is *Erysephalothrix muriceptica*.
- **Tyzzler's disease:** caused by *Bacillus pilliformis*.

## Viral disease: -

- Pox
- Lymphocytic choriomeningitis
- Tumours

## Mycotic infections: -

- *Mycoplasma pulmonis*, *Arthritidis* and *Murolyticum* causes chronic pneumonia, abscesses in joints and meningitis.

## Diseases of Rats: -

**Bacterial:** Salmonellosis, Leptospirosis, Pasteurellosis are the bacterial infections.

**Viral:** Encephalomyocarditis and Lacrimal duct infection.

## Parasitic infections:

- Sarcosporidiosis
- Entamoeba and Eimeria spp.
- Toxoplasma gondii

External parasites: Lice and Mange.

## Diseases of Hamster:

Hamster are mostly free from spontaneous diseases but **Salmonellosis** and **Mange** are common. Viruses like **Adenovirus** produces cancer and **Coxsackie-B virus** leads to diarrhoea.

**Canabolism:** This is a managemental disorder resulting into destroying of young ones by mother due to human smell after handling. The following care should be taken: -

- Rub the hands with bedding materials to remove human smell.
- First separate mother from young ones from cage.
- First put young ones in cage by rubbing them with bedding materials or cloth.

### Diseases of Guinea Pigs: -

Guinea pigs are also relatively disease free animals but **Salmonellosis, Streptococcal pneumonia** and **Pasteurellosis** are common bacterial diseases.

- Drinking water provided to lab. Animals should be purified, filtered & treated. Instead of using usual sanitizer, water is treated with Hcl at the dose level of 1ml/litre.
- The bedding materials used should be properly sterilized and be changed once or twice a week.
- Equipments like cages, feeders and waterers should also be sterilized.
- The feed/food supplied to lab animals should be balanced and sterilized.
- The house must be cleaned daily with disinfectants like phenyl, lysol etc.
- Entry of insects, mosquitoes, flies etc. must be prevented in lab. Animal houses.

- Isolation of diseased animals and appropriate timely treatment with special care for cleaning & disinfection of houses should be done.
- Quarantine for new entries with 2 or 3 weeks observation period to check biological transmission of diseases should be done.

# Transportation of laboratory animals

- Laboratory animals represent only a small fraction of animals moved in commerce and they differ from many in usually having a more defined health status.
- The objective is to move them in a manner that does not jeopardise their wellbeing or health status.
- Minimises controllable sources of stress and ensures their safe arrival at their destination.
- The type of journey, its duration, the physical environment during carriage, the design of the container, along with other factors influences the animals ' safety and wellbeing during the journey.



**General requirements:** Animal transportation includes the entire period from packing, through dispatch, carriage and receipt by the consignee to the unpacking of the animals at their final destination. It is important during the transportation process:

- that appropriate containers be used, constructed of strong, durable materials which meet or exceed all national and international guidelines.
- that the animals and their shipping containers be protected from adverse weather conditions such as precipitation, direct sunlight and high winds which can affect the ambient conditions within the container or the security of the container.

- that the animals be provided with an adequate supply of fresh or conditioned air that provides for their thermoregulatory, respiratory and metabolic needs.
- that the animals be protected from exposure to extremes environmental conditions, especially high temperatures.
- that the animals be prevented from escaping, or from falling out of the container, or extending appendages outside the container, or from experiencing other conditions that result in physical harm, including illness, injury or death.
- that factors that may cause animal discomfort or stress during the journey are recognised and, where possible, minimised.

## The health and welfare of animals:

- Animals to be shipped should be in good clinical health.
- Prior to packing, each animal should be examined.
- Animals should be excluded from shipment if there is behavioural or other clinical evidence of abnormalities would make them unsuitable for transportation.
- Shipment of pregnant animals should be avoided when possible.
- Transport of unweaned animals presents a considerable risk to their safety and well-being.
- Unweaned animals may, depending upon their age, have difficulty in regulating body temperature, be incapable of eating solid food and may be unfamiliar with, or unable to access, water sources within the container.

- Some species such as guinea pigs can be weaned at a very early age since they are capable of regulating body temperature and consuming solid food within a few days of birth.
- Shipping a lactating female with her young, especially over long distances, may result in her failing to care for her young and their death.
- Immunologically deficient, or immunocompromised animals, are commonly transported for research purposes.
- Some genetically modified animals can possess unrecognised immune defects that may alter their susceptibility to disease.
- Whenever these animals are transported, great care must be taken with all packing and handling and disinfection processes, to ensure that the animals will not be exposed to infectious agents.

## Health:

- health is an important concern in the transport of laboratory animals.
- In general, we can place infections into three groups as they relate to transportation:
  - (1) infections that pose a risk to domestic animals or humans;
  - (2) infections that pose a risk to the transported animals themselves; and
  - (3) infections that may produce no clinical disease but make the animals unsuitable for some types of research.
- The health certifications for transport of animals, required to allow them to move in and between countries, usually focus on infections that have human or agricultural/domestic animal significance.



Example of multiple species being held together in a ramp cart in the same airport staging area prior to loading on an aircraft.



Containers of mice and rats being loaded into the climate - controlled hold of an aeroplane that contains other perishable goods.

## Bedding, food and water:

- Bedding is commonly provided for laboratory animals in shipping containers. It serves several functions,
- the most important of which is the absorption of moisture from urine.
- water released from hydration sources such as water bottles or gelled water.
- to dilute and dry out faeces produced by the animals during transport.
- In the case of small mammals, bedding provides a source of insulation.
- Due to positional changes of the container during various stages of the transportation process.
- as well as due to the disturbances caused by the transportation environment.



- Animals in transit should be provided with access to food and water during the journey.
- Ideally, the food provided to the animals during shipment should be of the same type and microbiological status as that they were fed at the institution of origin.
- It is a good practice to provide sufficient food and water not only to allow for the anticipated length of the journey but also for at least an additional 24h of transportation in case of any unforeseen delays.
- Presentation of food and water should be done using a method that is appropriate to the past experience of the animals and to the behaviour patterns of the species.

- Access to drinking water during transit is important to help animals maintain hydration and thermoregulation.
- Water in liquid form can be provided in refillable water bowls in the case of certain large animals (eg, non- human primates) or through the use of water kits in the case of small animals.

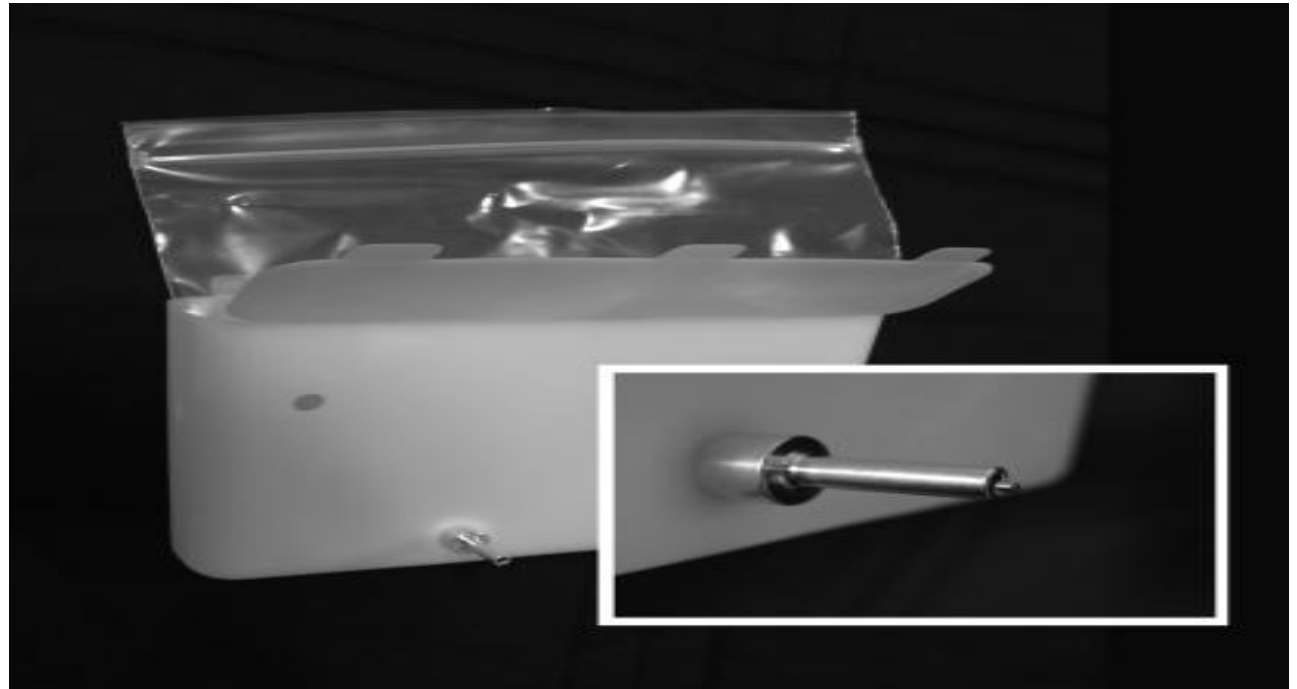

A drinking water kit consisting of a plastic holder, a sealable plastic bag for holding the water and a drinking valve for dispensing water

- Alternatively, a gelled water source can be provided.
- Gelled water is a hydrocolloid - stabilised material containing between 70 and 98% water by weight.
- Various sources of calories in the form of carbohydrates can also be added to the gelled water as well as flavouring and stabilising ingredients to prevent spoilage.
- When a large amount of gelled water is placed in a container in order to provide for extended journeys, it is important to assure that it is suitably affixed within the container as movement of this material within the container during transit could result in injury to small animals.

## Stress during transportation:

- Transient periods of stress will occur during transportation.
- This may be reflected in changes in heart rate, respiratory rate behaviour, food and water consumption, and in changes in the cellular and chemical composition of blood.
- there are species differences in what constitutes an environmental stress and the magnitude of its effects as well as the manifestation of those effects.
- The length of the journey is an important variable affecting stress in shipment.
- Avoidance of delays in shipment and transfers by good journey planning is important to minimise the overall level of stress associated with the journey.

- In order to enable animals to recover adequately from stress experienced during transport, it is very important that they are given a recovery period at their final destination prior to use in a research programme.
- This period of acclimatisation allows for recovery from the effects of stress during shipment and also allows the animals to adapt to changes in housing and husbandry.
- During transport, animals can lose varying amounts of body weight, often of the order of 10% or sometimes even a little more.
- Most of this loss occurs early in the transport process, much of which is attributable to the voiding of faeces and urine as well as decreased food and water intake.

## **Transport containers:**

- The specifications of animal transport containers (also termed shipping containers) can vary substantially depending upon the source (ie, commercial or locally constructed) and the local, national, or international guidance upon which their design is based.
- This guidance is organised by species and container type. Given its international acceptance.
- This guidance forms the basis for the minimum standards for container design.

## Container design and construction:

- The most common design of animal transport container is in the form of a rectangular box, the dimensions and shape of which are largely dictated by the species for which it is intended.
- Adequate ventilation is essential and the shipping container should be designed so that it can incorporate filtered or non-filtered ventilation apertures according to the microbiological status of the animals.
- Non-filtered transport containers are available for rodents and rabbits animals with restricted microbial status destined for research use should be transported under SPF conditions using microbiologically secure containers to protect them from infectious agents.
- Filtered containers require a viewing port (viewing window) to allow assessment of animals whilst in transit.
- This is particularly important for journeys that cross national borders where some form of official inspection may be required.



The back of a partially loaded, climate - controlled truck containing rodent shipping containers with integral ventilation. The air channels between the containers allow circulation of air across the filtered openings



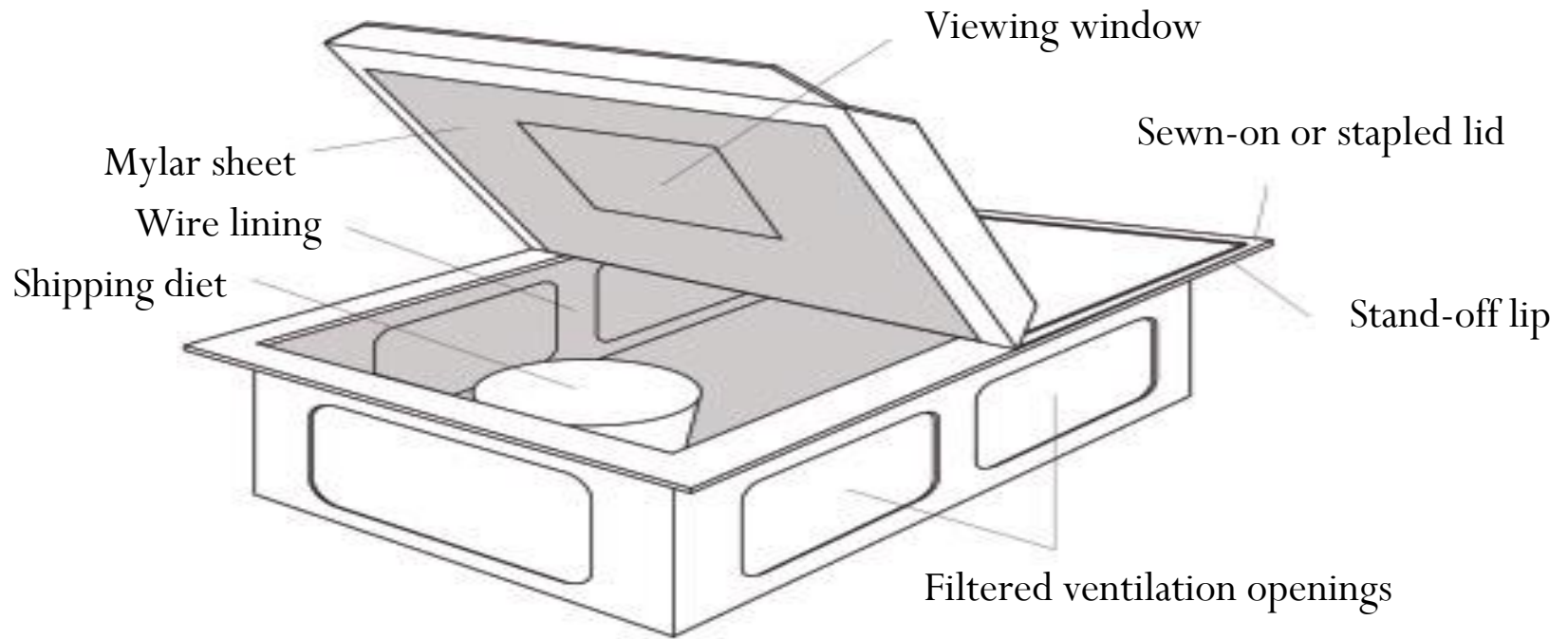

### Cardboard Shipping Container

Diagram of a cardboard shipping container used for transport of mice and rats. The principle features of this design of container are noted on the illustration.

- A variety of materials is available for container construction.
- For rodents and rabbits, the most commonly used materials are plastic or varying strengths of corrugated cardboard or corrugated polypropylene.
- Each container may be partitioned into separate compartments, or two or more separate, primary containers may be placed into an over shipper for transport.
- Corrugated cardboard and corrugated polypropylene are relatively cheap and easy to dispose of, or recycle, and therefore are commonly used in non-reusable containers.
- For transporting larger species, materials used to construct containers include wood, plastic, metal or fibreglass.
- Care must be taken to avoid using materials which adversely affect the health or welfare of the animal to be transported.

- The container should be durable, non - toxic and able to withstand stacking without causing damage or crushing.
- Wooden containers should be constructed so that the animal cannot bore, claw or bite them open at the seams or joints.
- Nails, bolts, staples, sharp edges or other protrusions, on which animals could injure themselves, should be avoided;
- all slats and uprights should have rounded edges and be installed so that the animals cannot entrap their extremities.
- The interior surface of the container must be of solid construction and can be protected to some extent from the effects of damp seepage due to urine by coating the inner surface with plastic or wax.
- For rodents that chew, a wire mesh lining may be applied over all internal surfaces, including the floor and filtered ventilation openings, of disposable cardboard shipping containers to prevent escape.